

MicroLED for digital headlighting

High-resolution light source for highly dynamic adaptive beams



Digital-headlighting applications call for highly dynamic adaptive-beam control and the highest resolution. Lumileds MicroLED is a high-resolution, 20k-pixel, monolithic light source designed for direct-imaging projection systems with small optics and the most compact built-in depth. Along with the ability to generate an infinite number of customized light distributions, it offers superior contrast for perfect road projection and sharp cut-off lines.

FEATURES AND BENEFITS

- 20k (246 × 82) high-resolution (40 μm pixel) monolithic light source for precisely controlled and highly dynamic AFS/ADB light distributions and novel road-projection functionalities
- Small light-emitting area of 32 mm² enables most compact direct-imaging optical system
- Superior contrast level for sharp cut-off lines and perfect road projection
- High efficacy >52 lm/W @ 85°C junction temperature for energy-efficient headlamp designs
- Embedded closed-loop LED supply control for energy-efficient operation
- Direct voltage-driver control eliminates the need for adaptation of existing LED driver modules

PRIMARY APPLICATIONS

- Adaptive driving beam (ADB)
- Adaptive front-lighting system (AFS) functionality with digital swiveling and leveling of high-beam/low-beam spots
- Driver-assistance road projections

Create your future digital beam with Lumileds MicroLED

Reference-system design and performance

- Total flux from light source: 2400 lm for high-beam (HB) drive
- Field of view: $21^\circ \times 7^\circ$, angular resolution: 0.085°
- 3 lenses: 2 x PMMA, 1 x PC; 40 mm outer-lens diameter
- Optical efficiency*: 33%
- Max. intensity for typical HB profile: $I_{max}^* = 58000 \text{ cd}$
- Max. intensity for single pixel: $I_{max}^* = 87800 \text{ cd}$
- Due to its small light-emitting area, Lumileds MicroLED also supports smaller optics: for example, a reduction to 30 mm lens height still yields 28% optical efficiency*.

* including 15% losses at the cover glass

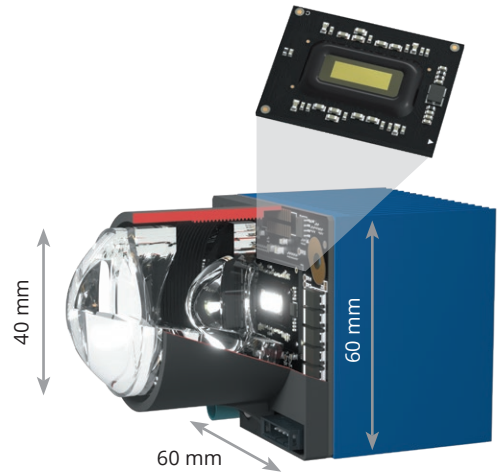

High pixel brightness and maximum pixel contrast for sharp road projections

- 10x10-pixel performance at max. current (3.8 mA) and 110 °C T_j : 0.55 lm/px and 109 Mcd/m²
- Single-pixel contrast: 1:150 over 120 μm (3 px)



Real projected images

Embedded closed-loop voltage control for best energy-efficiency operation

Best energy efficiency (> 52 lm/W) can be achieved by adjusting the LED supply voltage to an optimum value which depends on picture content and ambient conditions. We suggest using the control features embedded in our MicroLED to guarantee performance while minimizing development efforts.

- LDO-type constant current driver per pixel powered by external V_{LED} voltage supply
- Brightness control by 10-bit PWM dimming per pixel
- Continuous measurement of V_f for all pixels
- Integrated control-loop algorithms to minimize V_{LED} vs. V_{LDO} and V_f
- Two different ways to use control loop
 1. Digital readout via control interface
 2. Direct hardware control of V_{LED} voltage supply by using feedback connection (FB)

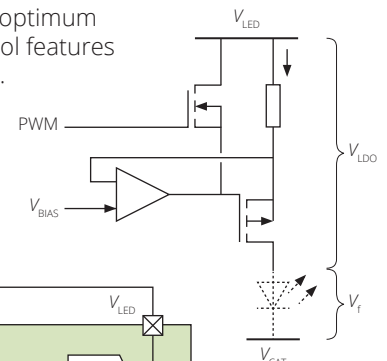
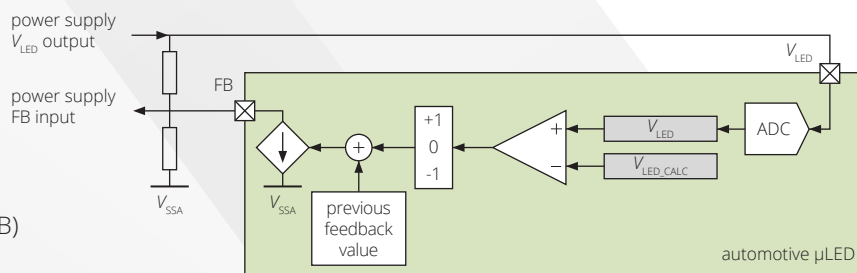

Lumileds MicroLED design-in support for customer systems

Lumileds offers comprehensive design-in support for MicroLED customer systems covering optical design, thermal management, and electronics. We also help with the implementation of both the image interface (parallel, SPI, UART) and control interface (UART, I²C).

Reference designs and laboratory electronics are available upon request.



Control software

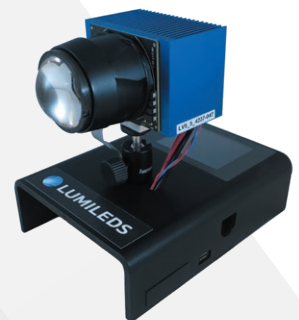

©2023-2024 Lumileds Holding B.V. All rights reserved. LUXEON is a registered trademark of the Lumileds Holding B.V. in the United States and other countries.

lumileds.com



Neither Lumileds Holding B.V. nor its affiliates shall be liable for any kind of loss of data or any other damages, direct, indirect or consequential, resulting from the use of the provided information and data. Although Lumileds Holding B.V. and/or its affiliates have attempted to provide the most accurate information and data, the materials and services information and data are provided "as is", and neither Lumileds Holding B.V. nor its affiliates warrants or guarantees the contents and correctness of the provided information and data. Lumileds Holding B.V. and its affiliates reserve the right to make changes without notice. You as user agree to this disclaimer and user agreement with the download or use of the provided materials, information and data. A listing of Lumileds product/patent coverage may be accessed at lumileds.com/patents.